



ArcSafe™, MultiClutch, ArcSafe™-SW

PATENT # 4,998,606

Robotic Collision Detection



INSTALLATION, OPERATIONS AND REPLACEMENT PARTS MANUAL

SERVICE QUALITY SOLUTIONS

TABLE OF CONTENTS

INTRODUCTION/WARRANTY	1
DESCRIPTION	2
SPECIFICATIONS.....	3
WIRING DIAGRAM.....	3
INSTALLATION AND SETUP	4
PART LIST.....	6

INTRODUCTION

Thank you for purchasing an American Weldquip product. The American Weldquip product you have purchased has been carefully manufactured, assembled and fully tested. This manual contains information on the installation, operation, maintenance and replacement part breakdown. Please read, understand and follow all safety instructions, warnings and procedures. Keep this manual handy for referencing installation, operation, maintenance and part ordering information. While every precaution has been taken as to the accuracy in this manual, American Weldquip, Inc. assumes no responsibility for errors or omissions. American Weldquip, Inc. assumes no liability for damages resulting from the use of the information contained in this manual. American Weldquip, Inc. shall have no liability to the buyer for consequential damages or expenses by any defect whatsoever.

WARRANTY

AMERICAN WELDQUIP MIG guns and parts are warranted to be free of defects in material and/or workmanship for the period of time listed below. For any product found to be defective under normal use, AMERICAN WELDQUIP, INC. at our option, will repair, replace or issue a credit for the value of the defective product. All warranty claims must be submitted by the original purchaser. Use of non-genuine AMERICAN WELDQUIP parts and/or consumables may damage and/or severely limit the performance of the equipment which may limit or void any warranties. AMERICAN WELDQUIP, INC. will not assume responsibility for incidental damages or expenses related to any defect. This warranty does not cover damage caused by misuse or abuse, accident, alteration of product, improper installation, misapplication, lack of reasonable care and maintenance, unauthorized repairs or modifications, loss of use while at a repair facility or other conditions that are beyond the control of American Weldquip, Inc.

A Return Authorization Number (RA#) must be attained from the factory for any product being returned for Warranty Repair or Replacement. All returned product must be shipped freight prepaid by the sender. No- charge replacements, repaired products, or credit will be issued, once the returned product has been evaluated and warranty condition has been verified. If an immediate replacement is required before proper warranty evaluation, a purchase order number is required and the goods will be invoiced. A credit will be issued once it is determined that a warranty condition exists.

STANDARD WARRANTY

All Semi-Automatic, Automatic, Robotic MIG TORCHES and Components	= 120 Days
MIG Torch Trigger Switches (Contacts only) -Excludes Smoke Extraction	= LIFETIME
Robotic Nozzle Cleaning Stations, Wire Cutter	= 90 Days
Robotic Peripherals, ArcSafe, Gun Mounts	= 90 Days
TIG POINT Tungsten Electrode Grinders	= 90 Days

LIMITED EXTENDED WARRANTY PROTECTION

This limited extended warranty protection expands coverage to loyal customers who use all GENUINE American Weldquip consumables. Customers filing a claim under the extended warranty will need to prove, by providing past invoices, that they have been purchasing and using Genuine American Weldquip consumables.

All Semi-Automatic, Automatic, Robotic MIG TORCHES and Components	= 1 YEAR
---	----------

MIG Torch Trigger Switches (Contacts only) -Excludes Smoke Extraction	= LIFETIME
MIG Torch Handles	= LIFETIME
Robotic Nozzle Cleaning Stations, Wire Cutter	= 90 Days
Robotic Peripherals, ArcSafe, Gun Mounts	= 90 Days
TIG POINT Tungsten Electrode Grinders	= 90 Days

ROHS COMPLIANT

RoHS (Restriction of Hazardous Substances) is an environmental law which addresses the European Union directive 2002/95/EC known as the RoHS Directive. The RoHS directive restricts the use of hazardous substances listed below in electrical and electronic equipment. While it is not a requirement to meet the directive in the United States, at this time, American Weldquip Inc. feels this is an important part of our "Go Green initiative. We have taken all reasonable steps to try to insure the supporting evidence regarding the absence of the restricted substances to support RoHS compliance.

For reference, the maximum concentration values of the restricted substances by weight in homogenous materials are:

Lead/Lead Components	- 0.1%
Mercury	- 0.1%
Hexavalent Chromium	- 0.1%
Polybrominated Biphenyls (PBBs)	- 0.1%
Polybrominated Diphenyl Ethers (PBDEs)	- 0.1%
Cadmium	-0.01%

For RoHS Certification of Compliance Letter on a particular product please visit our website – www.weldquip.com or email us at technical@weldquip.com or call 330-239-0317.



DESCRIPTION

WARNING: THE ARCSAFE, MULTICLUTCH AND ARCSAFE-SW USE A HIGH COMPRESSION SPRING. DO NOT DISASSEMBLE THE UNIT AS BODILY INJURY CAN RESULT.

The **ArcSafe™, MultiClutch™ and the ArcSafe™-SW robotic** safety mount is designed to provide the user with the ability to protect robot tooling, robots, and assembly fixtures from damage while the robot cell is in operation.

The ArcSafe and MultiClutch utilize an integrated switch designed to prevent damage to the robotic end of arm equipment and/or tooling. In the event of a “crash” situation with the end of arm equipment the switch activates the E-Stop circuit, thus stopping the robot movement.

The **NEW ArcSafe-SW** is specifically designed for use in robotic application where the crash protection is integrated into the robotic software package. Most integrated robotic collision detection software systems take time to come to a complete stop - especially with high speed movements. This is where the ArcSafe-SW offers additional protection over solid mount type devices.

The built-in spring deflection feature allows the ArcSafe-SW to deflect the end of arm equipment in the event of a crash. This additional safe guard provides the extra protection required to reduce or eliminate bent goosenecks, cracked insulating disks, and damaged tooling.

The ArcSafe and MultiClutch offer the air-assist option for use in applications of extremely fast movements or heavy payloads. See chart below.

Without Air			With Air Assist @ 100 PSA		
Mx,My	Mz	Fz	Mx, My	Mz	Fz
93 in. lbs.	168 in. lbs.	172 lbs.	275 in-lbs.	430 in.lbs.	500 lbs.

SPECIFICATIONS

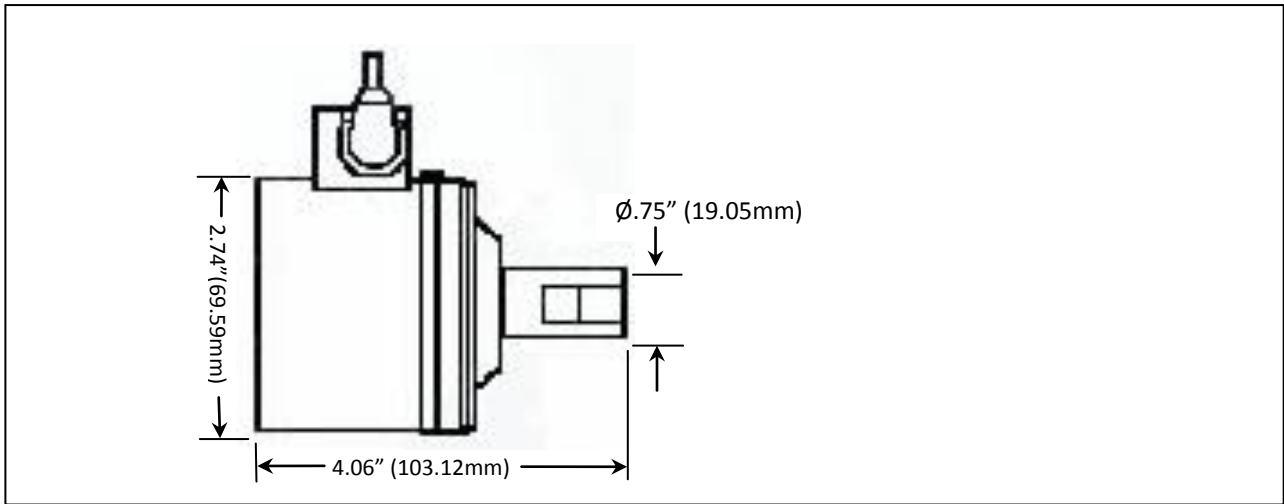

Weight- 1lb. 9 oz. (.709 KG)
Repeatability - \pm .001" (\pm .025mm)
Range Of Travel - 20° Pivot, 360° Rotation
 .50" (12.7mm) Compression

Spring Force

Mx, My = 93 in-lbs
 Mz = 168 in.lbs.
 Fz = 172 lbs.

Electrical – ArcSafe and MultiClutch Only

Micro Switch – Normally Closed
 Operational Voltage – 10 – 30 VDC

WIRING DIAGRAM

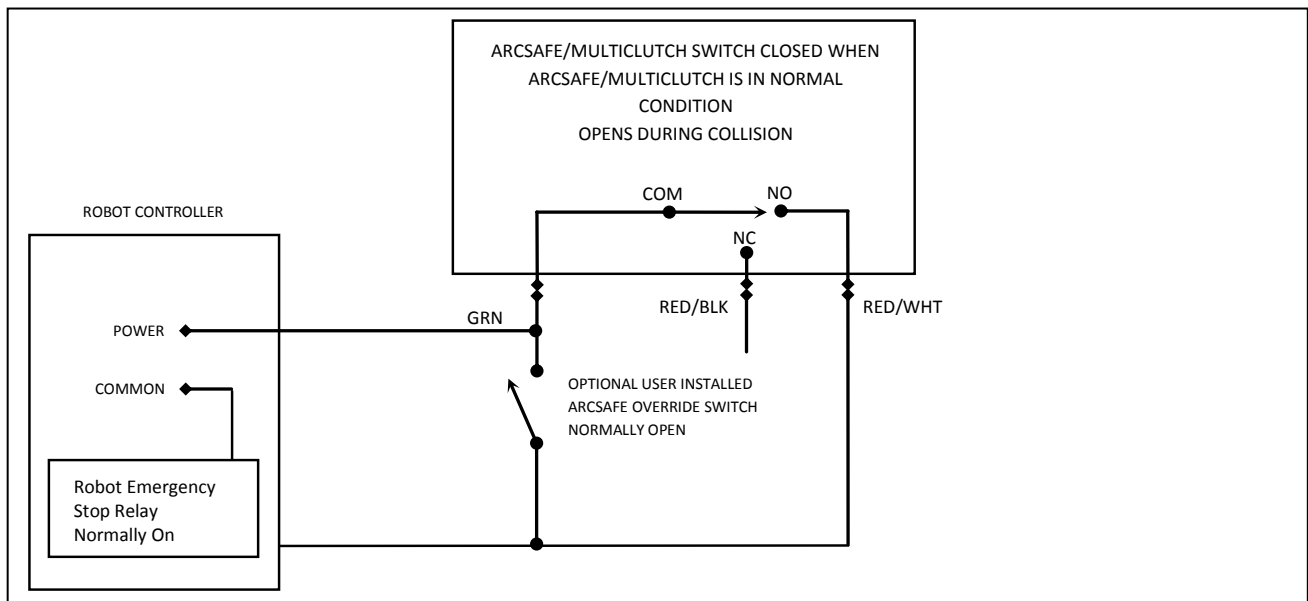

INSTALLATION AND SETUP

To insure proper installation position of torch or other hardware, orientate torch etc. in position with adaptor plate or insulating disk before mounting. Otherwise home position in relation to robot may not be correct.

1. Installing the Insulating Disk or Adaptor Plate

- a. Remove **ArcSafe** from the packaging.
- b. Install the proper insulating disk or adaptor plate(purchased separately) with correct mount screws (not supplied).
- c. Torque screws to 45 in.lbs. (5 nm).

2. Installing the ArcSafe, MultiClutch, ArcSafe-SW to the Disk or Plate

- a. Remove the dust boot.
- b. Select correct mounting hardware.
 - i. If using the Adaptor Plate – requires 4ea. M4 x 57mm
 - ii. If using the Insulating Disk – requires 4ea. M4 x 60mm
- c. Install the ArcSafe or MultiClutch to the insulating disk or adaptor plate with the screws provided.
- d. Torque screws to 45 in.lbs.
- e. Reinstall the dust boot.

3. Installing the Torch Mount on the ArcSafe or ArcSafe –SW

- a. Loosen wedge pin bolt but do not remove.
- b. Install torch mount on Arcsafe Shaft. Torch mount wedge pin must align with flat face on ArcSafe arbor shaft.
- c. Torque wedge pin screw to 50 in.lbs.
- d. Install torch in mount and secure by tightening gun holder screws. Torch to 45 in. lbs.

4. Installing equipment to MultiClutch

- a. The MultiClutch is supplied with a mounting flange. Customer must supply own equipment configuration to match mounting flange.

SIGN WIRING – ArcSafe and MultiClutch Only

The ArcSafe and MultiClutch use a single normally closed switch. Since the circuit is normally closed, the emergency stop relay will be **on** during normal operation. If power is lost, a wire breaks, or if there is a collision, the robot will emergency stop when the relay turns off. See Wiring Diagram – Page 3.

SETTING SENSITIVITIES – ArcSafe and MultiClutch Only

Collision detection is done by detecting piston movement using a small micro switch. The micro switch has been adjusted at the factory for optimal sensitivity. At times the user may want to change the reaction time of the switch to an overload condition. The switch can be adjusted for a more or less responsive E-STOP detection.

Older model ArcSafe's and MultiClutch's utilize a ball bearing and spring to activate the switch. New improved switch design was introduced in April 09 and is easily identifiable. The new design has distinct markings on the side of the switch housing – **LOCK** and **ADJUST**. The new design simplifies the adjustment procedures. The new designed switch is easily retro-fit able to the older design ArcSafe's and MultiClutch.

NEW DESIGN SWITCH ADJUSTMENT PROCEDURES

- 1) On the switch housing loosen the locking (marked **LOCK**) screw one (1) turn.
- 2) Using a short pigtail and ohm/continuity checking device or AWQ test box
 - a. Turn the adjusting (marked **ADJUST**) screw CCW up to one (1) turn until
 - i. Switch closes and shows continuity or;
 - ii. Light on test box illuminates.
 - b. Slowly turn the adjustment screw CW until
 - i. Switch opens and shows no continuity on test device or;
 - ii. Light on test box is not illuminated.
- 3) The ArcSafe and MultiClutch is now set for maximum sensitivity. In some applications you may wish to further reduce the sensitivity. To do so turn the adjustment screw further CW in 1/16 turn increments.
- 4) Turn the locking screw (marked LOCK) CW to secure the setting. The locking screw requires a snug fit. **DO NOT OVERTIGHTEN**



OLDER DESIGN SWITCH ADJUSTMENT PROCEDURES

Take care when adjusting switch height as wires are delicate.

To adjust the switch trip point:

- 1) Adjust the trip point by removing the (2) Allen screws securing the switch housing to the body and remove the switch assembly. **NOTE: Be careful when removing the switch housing from the body as there is a small spring and ball bearing in the clutch housing that could fall out.**
- 2) Loosen the switch mounting screws located on the side of the switch housing 1/4 turn. Screws should be snug enough so that switch does not float freely in mount.
- 3) Gently use a small screwdriver to rock and pry switch up above the surface of the connector block.
- 4) Normally the tip of switch should protrude approximately 1/32" from the face of connector block. To make less sensitive tip of switch should be position less than 1/32", more sensitive increase measurement.
- 5) Snug switch mounting screws to hold switch in housing
- 6) Remount connector block to side of clutch and tighten switch mounting

AIR-ASSIST

The air assist option can be added for use in applications of extremely fast movements or heavy payloads.

This option requires the use of a 1/8" NPT air fitting to accept 5/32 tubing, 5/32 tubing and an adjustable air regulator.

- 1) Remove the Red Plug from the air-assist port.
- 2) Thread the air-fitting into the ArcSafe and tighten.
- 3) Install the tubing to the air fitting.
- 4) Run the tubing to an air regulator. Adjust air- pressure to desired level.

PARTS LIST



Item #	Part Number	Description
1	502099	Switch Module Assembly – ArcSafe and MultiClutch models only
NS	900114	Ball Bearing ¼" diameter
NS	903402	Spring – Century #N-75
2	901729	Dust Boot
3	901696	Control Cable 20' – ArcSafe and MultiClutch models only
4	900299	Air Assist Plug – 1/8" NPT

Item #	Part Number	Description
NS	502729	Mounting Bolts for use with Insulating Disk – M4 X 60mm
NS	502728	Mounting Bolts for use with Adaptor Plate – M4 X 57mm
NS	900626	M4 Lockwasher
NS	KAR-TGL	ARCSAFE TOGGLE / FRONT COVER KIT, STD
NS	KASM-TGL	ARCSAFE TOGGLE / FRONT COVER KIT, METRIC
NS	KMC25-TGL	MULTICLUTCH TGL / FRONT COVER / FLANGE KIT
NS	501602	ARCSAFE BODY
NS	501603	ARC SAFE PISTON
NS	501607	ARCSAFE PIVOT PIN
NS	501882	ARCSAFE CYLINDER BODY EXPORT
NS	503246	MC25 FLANGE
NS	503248	MULTICLUTCH KEY, 1/8 X 1/8 X 3/8
NS	503249	MULTICLUTCH THD INSERT, M6 X 1 X 9
NS	503271	HEAVY SPRING
NS	900230	LOCKWASHER #8
NS	900246	ARCSAFE 1/8" X 1/4" SS DOWEL PIN
NS	900742	ARCSAFE 8-32X 7/8 SHCS
NS	901169	PISTON O-RING FOR AS-CLUTCH
NS	901476	ARCSAFE 6-32 X 1 1/2" SHCS
NS	901478	ARCSAFE 0-80 X 3/8" SS PAN HD SCREW
NS	901479	ARCSAFE #0 SS SPLIT WASHER
NS	901642	ARCSAFE SHFS M6 X 16mm
NS	901706	ARCSAFE MEDIUM SPRING
NS	901871	ARCSAFE SOFT SPRING
NS	901907	ARCSAFE SHCS, M4 X 22mm
NS	901926	ARCSAFE STEM FINISHING CAP
NS	902448	8/32 X 2.25 SCREW

NOTES:



AMERICAN WELDQUIP

1375 Wolf Creek Trail – P.O. Box 397
Sharon Center, Ohio 44274
330-239-0317 Telephone / 800-949-9353 Fax

